

Article_18_An_Analysis_on_the_Impact_of_Participatory__1.pdf

by

Submission date: 14-Aug-2018 05:02PM (UTC+0700)

Submission ID: 989883175

File name: Article_18_An_Analysis_on_the_Impact_of_Participatory__1.pdf (900.3K)

Word count: 7620

Character count: 42598

An Analysis on the Impact of Participatory Budgeting and Procedural Fairness Toward Manager's Commitment and Performance

Widia ASTUTY

Faculty of Economics, Universitas Muhammadiyah Sumatera Utara, Medan, Indonesia,
E-mail: widiaumsu@gmail.com

Abstract This study aims to test the effect of participatory budgeting and procedural fairness on the manager's commitment and performance either have simultaneous or partial effect. The method of the research used was a survey method that conducted at the pawnshop in North Sumatra with the respondents of the managers in branch offices. The data used is primary data by collecting data through questionnaires. The analysis method used is descriptive-analytical verification. The effect model analyzed using a structural equation model to analyze the pattern of causal relationships between variables and determine the direct, indirect and total effect of some variables. The results showed that participatory budgeting and procedural fairness simultaneously have a significant and positive effect on the manager's commitment; participatory budgeting has a significant and positive effect on the manager's commitment; procedural fairness has a significant and positive effect on the manager's commitment; participatory budgeting, procedural fairness and manager's commitment simultaneously has a significant and positive effect on the manager's performance; the effect of participatory budgeting has a significant and positive effect on the manager's performance; the procedural fairness has a significant and positive effect on the manager's performance; the manager's commitment has a significant and positive effect on the manager's performance.

Key words Participatory budgeting, procedural fairness; manager's commitment, manager's performance

1. Introduction

A pawnshop as one of the State-Owned Enterprises (SOEs) in the Ministry of Finance that deliver short-term loans. This pawn lending have been enjoyed, not only for the economically weak people but has been penetrated into the middle to upper level of income who live in rural and urban areas. To improve the effectiveness and efficiency of the pawnshop, the government intended to change the form of the pawnshop's company, however, there are consequences for the fundamental changes which include; (i) pawnshop have dual functionality that are to serve the community and profit orientation; (ii) the organization is based on decentralization; (iii) decrease in interest rates; (iv) additional in credit limit; and (v) changes in capital structure.

As a non-bank financial institutions, the pawnshop providing services to the community aims to cultivate a profit by exploiting all the potential based on the principles of management of the company. The capital of the pawnshop originally comes from the government through the state budget, but now the capital structure changed to; (i) the foreign capital which consists of the national budget and profits are reserved before this pawnshops established; (b) loan from BRI (People's Bank of Indonesia); and (ii) the capital from the pawnshop itself which consists of: (a) retained earnings; and (b) various kinds of reserves. While, the fund management at branch offices based on the principles of money cash management. With this principle, it is expected that the funds are not embedded too much, so it does not interfere with the business operation. This is in accordance with the policies outlined by the directors, so that the financial management of the company is really effective and efficient.

The organizational structure of the pawnshop can be seen clearly by the duties, authority and responsibilities of each personnel as well as the relationship between other sections vertically or horizontally. Maryanto (2004) posited that the pawnshop with a decentralized organization has given authority to the regional Office to prepare an annual budget that includes budget for the branches within its territory. Thus each unit of the organization can work more effectively and efficiently in achieving the expected profit whereby the pawnshop has done several ways, include; (i) engaging the branch office manager in the preparation of the budget due to responsibility for achieving the company's earnings through the realization of revenue and control costs occur in each of the organization units; (ii) engaging the branch office manager in the decision making process related to the organizations (Maryanto, 2004). Although the branch managers involved in budgeting and decision-making process, but the results of the preliminary study are interesting phenomenon to do more in terms of assessment of the level of involvement of the manager of a branch office in the preparation of the budget. When the decision on the allocation of the budget to be unjust, then the manager will look at how the decision-making process or procedure is determined (Folger, 1986). He added, if the budget allocation decision having a fair procedure, then it will affect the performance.

According to Hansen and Mowen (2005: 267), an organization needs to translate the overall budget strategy into plans and short-term goals and long term. A budget is a plan prepared quantitatively, generally in the size units of money, which includes a specific time, usually one year. This preparation of a budget helps the management to communicate the goals of the organization to all managers. In addition, the budget is the information for the managers to realize the budget through analyzing specific needs and behavioral patterns. Moreover, the budget process is basically a negotiation between the managers in setting up the goals and actions which followed with its' implementation. The budget that has been approved by the supervisor contains income expected to be earned in the fiscal year, and sources must be used to achieve overall corporate objectives.

According to Siegel and Marconi (1989: 199), an organization run by humans and the actual performance evaluation is an assessment of human behavior in carrying out its role in the organization. Therefore, the budget often can have an impact on the psychological and behavioral responsibility of the managers. Budget may lead to functional and dysfunctional behavior. In other words, there are positive and negative effects of the budget on the motivation and behavior of those involved in the budget. Functional behaviors would help and support the achievement of goals, otherwise dysfunctional behavior could be an obstacle to the achievement of corporate goals. Negative behavior arises because of the pressure by the budget system adopted by managers that decreased the performance (Siegel and Marconi, 1989: 128). While positive behavior arises when individual manager and organizational goals are combined to achieve it.

Research has shown that the participation of the budget has a positive effect on the motivation of management (Anthony and Govindarajan, 2003: 420), while participation refers to a process of shared decision making by two or more parties initiated for the future outcomes. To see the extent of the performance achieved by the managers can be seen from the report or accounting information presented by companies or called as management accounting information. This management accounting information is needed by managers as the information useful in the decision-making process. While, the accounting information also needed in the process of budget preparation and control used for assessing the performance of the managers. Anthony and Govindarajan (2003), suggests that the process of budget preparation and control of the business and operations embodied aspects of human behavior. The budget is basically the end result of negotiations between the units' managers or as the central of responsibility with their supervisor to determine the goals and actions to be performed. Thus, the critical issue in budgeting lies in the aspect of human behavior that is contained in the budget.

The process of planning and control in budgeting and business operations are basically the process of defining the role for managers in the levels of the organization to carry out the activities in achieving corporate goals which include setting up the resources to carry out the obligations. The prepared budget as the a plan that will guide the implementation and controlling tool in its execution, thus the deviation occurred on the plans can be immediately known the person in charge who was responsible and followed by acting immediate corrective.

To see to what extent a responsibility center has reached the target, it can be seen from the report of a central achievement of accountability. The work of a responsibility center is successful when the goals stated in the articles can be achieved, otherwise considered less successful when the goals stated in the budget is not achieved. The results of these comparisons may lead to a difference (deviation). Significant deviations needs to be further analyzed, in order to know what factors that cause such deviations. By knowing the factors that cause the occurrence of irregularities, will allow management to undertake corrective action, so that deviations from this budget can be eliminated or at least minimized, to avoid any wastage and encourage managers to improve performance. Meanwhile, the role of managers in planning and controlling budgets and business operations, are conducted according to the principles "bottom up-top down" that each organizational unit managers to create and submit their respective draft budget to the budget committee by considering the existing economic resources, then combined with mutual consent.

Here it appears that the managers' involvement or participation in budgeting began from designing the central budget of their accountability respectively, to the implementation and control. Thus through this participation, the managers feel their aspirations are valued and have an influence on the formulation of the budget. The inconsistent results of these findings are encourage the researchers to evaluate various factors or variables that may affect the relationship between the participatory budgeting with the managers' performance.

2. Literature review

Individuals within an organization are often influenced by their perceptions of the budget fairness. Gener (54), one would compare the budget that has been set up for him with other parties at the same level. An individual's perception of fairness is based on the target and process that becomes the motivation for individuals to achieve a set budget (Lindquist, 1995; Libby, 1999).

One of the theory that tested the fairness is the referent cognitions theory. According to this theory, when individuals receive unfair outcomes, their judgment becomes attached to referent or other parties (Folger, 1986). Therefore, one would compare the outcomes they receive with referent outcomes, such outcomes were due to receive or received by others (37) with equivalent positions. The fairness can be viewed from two sides, namely distributive fairness and procedural fairness. Distributive justice is an individual's perception of the fairness distribution of organizational outcomes, while procedural justice relates to fairness and feasibility of the procedures used to allocate or distribute the decisions within the organization (Kreitner and Kinicki, 2000).

This study analyzed the effect of managers' perceptions of fairness in terms of procedural fairness, with the following considerations: First, the participation of managers in budgeting allows managers to influence the allocation or distribution of the budget. Second, the principle of the procedure is a mechanism for determining the decision, including the decision to distribution. This means whether the allocation is fairly done or otherwise will depend on how the budget allocation decision procedures are been set. Perceptions of managers on procedural justice if the decision on the allocation or distribution of the budget is set based on reasonable or fair procedure. Similarly, although the manager in carrying out its activities are often faced with budget constraints, but if the budget allocation decision is determined based on a fair procedure, the top managers' (40) perceptions of procedural fairness will increase. Cropanzano and Folger (1991) suggested that if the process used to decide the amount of budget allocation is reasonable, then the subordinate actions will lead to improve performance. Thus top managers' perceptions (27) of procedural fairness is an important factor that must be considered in designing a budget.

The concept and measurement of commitment to goals is a key aspect of the theory of goal setting. According to this theory, a commitment to the goals is refers to an individual commitment in achieving the organizations' goal. According to Locke (1981) in Chong and Chong (2002), the manager's commitment is a strong determination to achieve a goal on the budget that continually striving to reach it all the time. The commitment to a goal is a level of individual commitment to achieve certain goals. Individuals who have a high commitment to the objectives of the budget will always increase its efforts to achieve those goals, so it will have an impact on performance. In contrast, individuals who do not have a commitment to achieve the goal on budget will result in a lower performance level. Murray (1990) and

Wentzel (2002) found the evidence that the manager's commitment has positive influence on the performance of managers.

The performance is the success rate of individuals or managers in carrying out the work. In this research plan, the manager at the pawnshop branch office becomes the object of the performance measure as the managers of profit centers. As the profit center managers, the manager is responsible for the achievement of the unit profit organization they lead. Their performances are based on the difference between revenue with expenses gained that should be realized (Hansen and Mowen, 2005; Anthony and Govindarajan, 2003). In relation to the previous description about the participatory budgeting and procedural justice, it has raised questions about whether the two variables actually affect the manager's commitment to the goals on budget or otherwise. Or is there any relationship among these variables in the performance of managers. Similarly with the commitment of the managers on budgetary purposes that may have an affect to their performance. Accordingly, the reciprocal relationship and interplay between these factors will be tested in this study. Thus, the study examines the effect of participatory budgeting and procedural fairness to the commitment and performance of managers is interesting to be conducted in the development of sciences. The following are the considerations of the researchers to conduct a study of these variables:

Firstly, the studies that examine the effect of participatory budgeting on the performance of the manager still showed inconsistent results. According to Govindarajan (1986), in order to reconcile the inconsistent results, he proposed to use the contingency approach through evaluation of various conditional factors, so as to improve the effectiveness of participatory budgeting that influence on the performance of managers. This study uses the conditional factor of commitment as an intervening variable. The intervening variable is a variable that is affected by a variable and affect other variables (Shields & Young, 1993; Shields & Shields, 1998).

Secondly, by incorporating a different procedural fairness variable both in terms of the structure of the model and the findings of existing research, it is expected to further enrich the models in the field of management accounting and the behavioral aspects of accounting to guide the behavior of members of the organization in achieving the goals on budget as well as to shows the originality of this study.

Thirdly, this study of pawnshop assessment is done for an effort to increase the commitment of the managers in the organization, so that the expected achievements to be achieved. The achievement of performance at each branch offices is very important because it is not only used to fulfill obligations to third parties but also to provide bonuses or to open a new branch office of pawnshop in other areas. With the increasing number of pawnshop branches, the role of pawnshop is expected to assist the government programs to improve the societal welfare economically.

3. Methodology of research

This study aims to obtain a description of the effect of participatory budgeting and procedural fairness on commitment and performance managers at the pawnshop in North Sumatra province. Both two types of descriptive and verificative methods are used to analyze the data of the study. The behavioral aspect of accounting on management accounting is used as the basis of the study with the emphasis on budget issues. Types of relationships between variables are causality in which the independent variable is participatory budgeting and procedural fairness serves as a cause of the variable, while the dependent variable is the commitment and performance of managers as a effect of the variable.

3.1. Operationalization of variables

Table 1. Operationalization of variables

Variable	Dimension	Indicator	Item No.	Scale
Budgeting Participatory (X ₁) Milani (1975), Kennis (1979), Brownell and Mc Innes (1986), Wentzell (2002), Widia (2012)	Participation of managers	1. Participation in budgeting	1	Ordinal
		2. The opportunity to propose a budget	2	
		3. The effect of the proposal on the final approved budget	3,4	
		4. Participation in the revised budget	5	
		5. Direction of top-level corporate managers	6	

Variable	Dimension	Indicator	Item No.	Scale
	Influence/ Benefits of Participation	1. Clarify the purpose of the budget 2. Creating the goal congruence 3. Increasing the manager's commitment 4. Increase the achievement	7 8 9 10	Ordinal
Procedural Fairness (X_2) Lau and Lim (2006), Wentzell (2002)	Budget Preparation Procedures Control Procedures	1. Consistency 2. Timeliness 3. Independence in preparing the draft budget 4. Compliance with ethical and moral procedures 5. Accuracy of information 6. The attention of top-level managers 7. Procedure budget evaluation 8. Feedback budget 9. Procedure promotion 10. Giving bonuses	11 12 13 14 15 16, 17 18 19 20 21	Ordinal
Manager's Commitment (Y) Hollerbeck <i>et al.</i> (1989), Wright <i>et al.</i> (1994), Chong and Chong (2002)	The Importance of Goals of The Budget	1. Acceptance of budget goals as personal goals 2. Willingness to implement budget 3. Satisfaction/pride 4. Failure feeling if the budget is unachieved 5. Develop a sense of challenge 6. Sense of responsibility and great care	22 23 24 25 26 27	Ordinal
	Level of Effort Required to Achieve Objectives	1. Willingness to work hard 2. Inspiration looking for the best way to improve performance 3. Willingness to provide the best capability	28 29 30	
Manager's Performance (Z) Outlay, (1978), Siegel and Marconi (1989)	Earnings Achievement	1. Control/cost efficiency 2. Achievement of revenue	31 32	Ordinal

Population and Instrument Tests

The population of this study is all 212 the pawnshop branches located in North Sumatra where the respondents are the individual of branch managers that have the responsibility as the managers of profit center. This study used a census of the entire population as the unit of analysis. Both validity and reliability are used in this study. Validity test results have shown that all of the items are valid, while the reliability coefficient of the questionnaire examining the five variables are all greater than 0.7, so that it can be concluded that the instrument measures used in this study have given consistent results.

5

Analysis and Hypothesis Test

The analysis used to test the hypothesis in this study is the Structural Equation Modeling (SEM) using AMOS 16. SEM is a set of statistical techniques that allow the testing of a set of relationships that are relatively "complex" simultaneously (Ferdinand, 2002). Since all variables are in ordinal-typed of scale, while the use of path analysis requires the data to be in interval, then the original data transformed into ordinal interval data via the method of successive interval with the following steps:

- 1) Pay attention to each statement (item);
- 2) For the said statement, the number of respondents is determined to have a score of 1, 2, 3, 4, and 5 in order to obtain the frequency (F);
- 3) Each frequency is divided by the total number of respondents in order to obtain the proportion (p);
- 4) The proportion is summed up sequentially for each answer's scores in order to obtain the cumulative proportion (pk);
- 5) Using the chart interval, the Z value is calculated for each cumulative proportion obtained;

6) Determine the value of the interval for each value of Z with the following formula:

$$SV = \frac{\text{Density at lower limit} - \text{Density at upper limit}}{\text{Area under upper limit} - \text{Area under lower limit}} \quad (1)$$

Furthermore, as a benchmark for the closeness to state the high and low estimates of the indicator, the correlation relationship or the strength of the effect is referring to the standard categories of Guilford (Guilford, 1956: 145) with the following criteria:

Table 2. Criteria of Relationship Level

Correlation Value	Particular
< 0.20	The relationship is low or the influence is weak which almost negligible.
0.20 – 0.40	The relationship is low or the influence is weak.
0.40 – 0.60	The relationship/influence is moderate.
0.60 – 0.80	The relationship/influence is high.
0.80 – 1.00	The relationship/influence is very high.

Source: Guilford (1956: 145)

4. Findings

The Collection of Data

The data were obtained from the respondents; the managers of pawnshop branch offices in North Sumatra using a questionnaire survey tool. Below is the table of questionnaires rate of return from respondents:

Table 3. Distribution of Questionnaires

Particular	Total	Percentage
Distributed Questionnaires	212	100%
Returned Questionnaires	207	97.64%
Unreturned Questionnaires	5	2.36%
Questionnaires Analyzed in the Research	202	95.28%

Hypothesis Test

The structural model is built by a relationship among latent variables (construct) whereby the indicators have been tested for validity and reliability in the measurement model. In accordance with the research paradigm that has been stated previously, the structural relationship between variables is composed of two s₄-structures, namely:

1. Effect ₄₄ participatory budgeting and procedural fairness to the manager's commitment,
2. Effect of participatory budgeting and procedural fairness, and commitment to the performance of managers.

The Effect of Participatory Budgeting and Procedural Fairness on Manager's Commitment

The sub-structures analyzed in this study is the participatory and procedural fairness affect either simultaneously or partially on the manager's commitment. Path diagram of structural equation model of the influence of participatory budgeting (X₁) and procedural fairness (X₂) to the managers' commitment (Y), is presented in Figure 1 below.

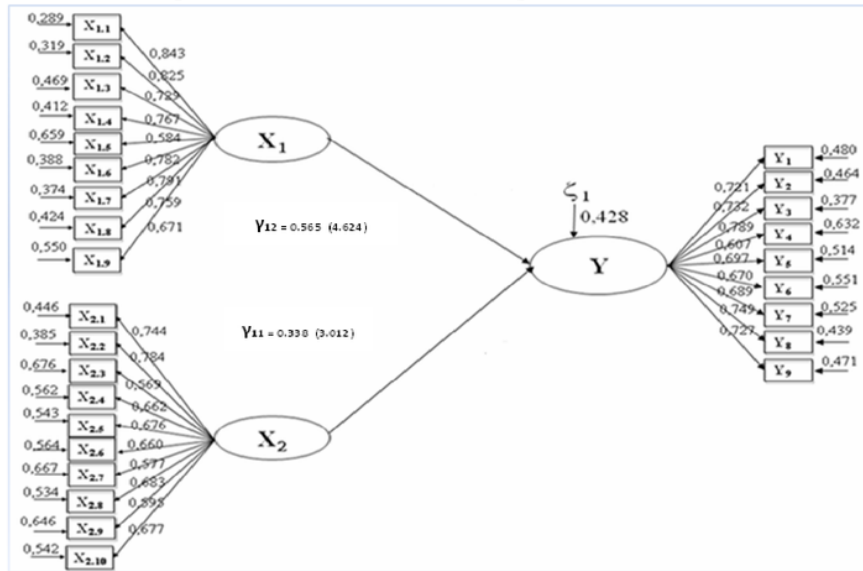

Figure 1. Path diagram of structural equation model of the influence of participatory budgeting (X₁) and procedural fairness (X₂) to the managers' commitment (Y)

Structural equations for the first model is formulated as follows:

$$Y = 0.338X_1 + 0.565X_2 + \zeta_1 \quad (2)$$

The influence coefficient of participatory budgeting (X₁) on the manager's commitment (Y) is 0.338 and a coefficient for procedural fairness (X₂) on the managers' commitment (Y) is 0.565. To examine the effect of variables which hypothesized partially using t test with the test criteria of α is 0.05, the limit values for significant test is 1.96. From these results, it can be seen the level of influence of participatory budgeting and procedural fairness to the manager's commitment either simultaneously or partially. The calculated t consists of the direct, indirect and total effect. The magnitude of the direct, indirect and total effect of participatory budgeting and procedural fairness are presented in table 4 below.

Table 4. Effect on Level of Participatory Budgeting (X₁) and Procedural Fairness (X₂) on the Manager's Commitment (Y)

Variable	Formula	Effect(%)		
		Direct	Indirect	Total
Participatory Budgeting (X ₁)	$\gamma_{YX_1}^2 (0.338^2 \times 100 \%)$	11.42%		18.37%
	$\gamma_{YX_1} \times r_{X_1X_2} \times \gamma_{YX_2}$ (0.338 × 0.364 × 0.565) × 100 %		6.95%	
Procedural Fairness (X ₂)	$\gamma_{YX_2}^2 (0.565^2 \times 100 \%)$	31.92%		38.87%
	$\gamma_{YX_2} \times r_{X_1X_2} \times \gamma_{YX_1}$ (0.565 × 0.364 × 0.338) × 100%		6.95%	
Simultaneous Effect of X ₁ and X ₂ on Y ($R^2_{Y.X_1X_2}$)				57.24%
Other Variables on Y (ζ_1)				42.76%

Source: Data Output SPSS

The Effect of Participatory Budgeting, Procedural Justice, Managers' Commitment on the Manager's Performance

The sub-structures analyzed in this study is the participatory, procedural fairness, manager's commitment affect either simultaneously or partially on the manager's performance. Path diagram of structural equation model of the influence of participatory budgeting (X₁) and procedural fairness (X₂), managers' commitment (X₃) on the manager's performance (Z) is presented in figure 2 below.

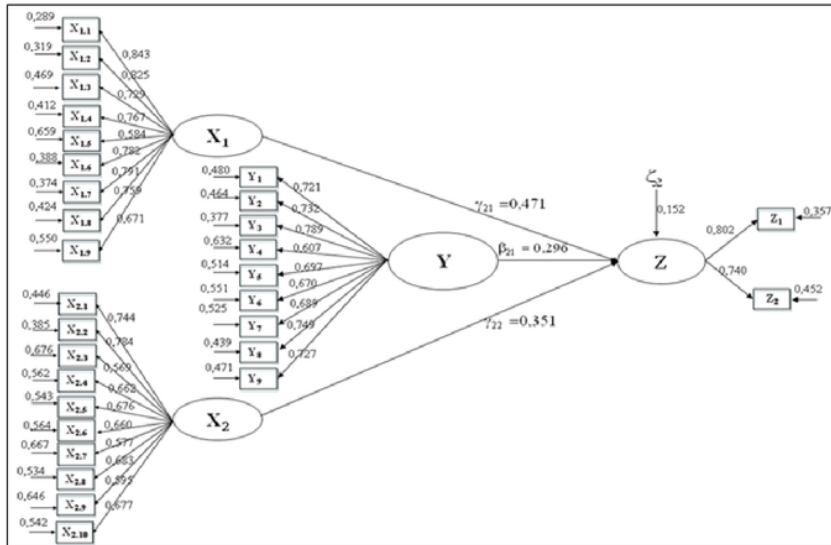

Figure 2. Path diagram of structural equation model of the influence of participatory budgeting (X₁) and procedural fairness (X₂), managers' commitment (X₃) on the manager's performance (Z)

Structural equations for the first model is formulated as follows:

$$Z = 0.471X_1 + 0.351X_2 + 0.296Y + \zeta_2 \tag{3}$$

The influence coefficient of participatory budgeting (X₁) on the manager's performance (Y) is 0.471, a coefficient for procedural fairness (X₂) on the managers' performance (Y) is 0.351 and a coefficient for manager's commitment (X₃) on the managers' performance (Y) is 0.296. To examine the effect of variables which hypothesized partially using t test with the test criteria of α is 0.05, the limit values for significant test is 1.96. From these results, it can be seen the level of influence of participatory budgeting, procedural fairness and manager's commitment on the managers' performance either simultaneously or partially. The calculated effect consists of the direct, indirect and total effect. The magnitude of the direct, indirect and total effect is presented in Table 5 below.

Table 4. Effect on Level of Participatory Budgeting (X₁), Procedural Fairness (X₂) and Manager's Commitment (Y) on the Manager's Performance (Z)

Variable	Formula	Effect (%)		
		Direct	Indirect	Total
Participatory Budgeting (X ₁)	$\gamma_{ZX_1}^2 (0.471^2) \times 100 \%$	22.18%		35.79%
	$\gamma_{ZX_1} \times r_{X_1, X_2} \times \gamma_{ZX_2}$ (0.471 x 0.364 x 0.351) x 100 %		6.02%	

Variable	Formula	Effect (%)		
		Direct	Indirect	Total
Procedural Fairness (X ₂)	$\gamma_{ZX_1} \times r_{X_1Y} \times \gamma_{ZY}$ (0.471 x 0.544 x 0.296) x 100%		7.58%	25.49%
	$\gamma_{ZX_2}^2 (0.351^2) \times 100\%$	12.32%		
	$\gamma_{X_1X_2} \times r_{X_1X_2} \times \gamma_{ZX_1}$ (0.351 x 0.364 x 0.471) x 100%		6.02%	
Manager's Commitment (Y)	$\gamma_{X_1X_2} \times r_{X_2Y} \times \gamma_{ZY}$ (0.351 x 0.688 x 0.296) x 100 %		7.15%	23.49%
	$\beta_{ZY}^2 (0.296^2) \times 100\%$	8.76%		
	$\beta_{ZY} \times r_{X_1Y} \times \gamma_{ZX_1}$ (0.296 x 0.544 x 0.471) x 100 %		7.58%	
$\beta_{ZY} \times r_{X_2Y} \times \gamma_{ZX_2}$ (0.296 x 0.688 x 0.351) x 100%				7.15%
Simultaneous Effect of X ₁ X ₂ and Y on Z ($R_{Z..X_1X_2Y}^2$)				84.77%
Other Variables on Z (ζ_2)				15.23%

Source: Data Output SPSS

5. Discussions

The Simultaneous Effect of Participatory Budgeting and Procedural Justice to the Manager's Commitment

The results of calculations for the hypothesis of the effect of participatory budgeting (X₁) and procedural fairness (X₂) on the manager's commitment (Y) simultaneously can be seen in table 6 below:

Tabel 6. The Effect of Participatory Budgeting (X₁) and Procedural Fairness (X₂) Simultaneously to Manager's Commitment (Y)

Variable	Path Coefficient	Direct Effect	Indirect Effect	Total
(X ₁)	0.338	11.42%	6.95%	18.37%
(X ₂)	0.565	31.92%	6.95%	38.87%
Total Effect Simultaneously				57.24%
Other Variable on Y				42.76%

Source: Data Output SPSS

The analysis showed that the participatory budgeting and procedural fairness affect simultaneously the manager's commitment. The influence of these two variables to the manager's commitment is positive at 57.24%. The results of this study indicate that the magnitude of the manager's commitment can be explained by the participatory budgeting and procedural fairness, while 42.76% is explained by other variables. If the magnitude of this effect is interpreted based on the level of relationship strength proposed by Guilford (1956: 145), the participatory budgeting and procedural fairness effects are still sufficient. Moreover, the effect of procedural fairness variable was higher than the variable of participatory budgeting. In this regard, the efforts to increase manager's commitment is to provide wider opportunities to be involved in the process/decision-making procedures of the organization.

The Effect of Participatory Budgeting on Manager's Commitment

The participatory budgeting is hypothesized to have a significant influence on the manager's commitment. To prove this hypothesis, the testing based on the survey data can be seen in table 7 below.

Table 7. Significance Test on the Effect of Procedural Fairness (X₁) on the Manager's Commitment (Y)

Variable	Coefficient Effect	t	Critical t	Conclusion
Participatory budgeting	0.338	3.012	1.96	Positive and Significant Effect
Direct Effect = 11.42%		Indirect Effect = 6.95%		Total Effect = 18.37%

Source: Data Output SPSS

In table 7 shows that the path coefficient of participatory budgeting to manager's commitment is 0.338. The positive relationship of participatory budgeting on manager's commitment means that the higher the degree of participatory budgeting, the higher the magnitude of the manager's commitment. Furthermore, the value of t-test path coefficients of participatory budgeting variable on manager's commitment is 3.012. It is also found that t-test value is greater than t-table (1.96), thus concluded that participatory budgeting significantly influence the managers' commitment. Meanwhile, the effect of participative budgeting on manager's commitment amounted to 18.37%. If the magnitude of this effect is interpreted based on the level of the strong relationship proposed by Guilford (1956: 145), then the effect of participatory budgeting on the manager's commitment is very low or weak. The results are consistent with the findings by Chong and Chong (2002), Wentzel (2002), Mulyasari and Sugiri (2004) states that participatory budgeting has a positive and significant effect on the manager's commitment. This a very weak effect of participatory budgeting due to the participation of branch manager in preparation of budget are not in line with expectations in carrying out the role as the manager of the company's organizational unit. In addition, although the branch managers are participated in designing the preparation of budget but when there is a change in budget, it often poorly communicated. This resulted because the branch managers face difficulty in achieving the targets on budget that have been set earlier, thus they are less committed to the organization. To increase the manager's commitment is by providing a wider role in the preparation of the budget. In other words, the pawnshop particularly those in regional offices need to improve the application of participative management whereby a wider role is given, means it required to increase the responsibilities in achieving the targets on the budget.

The Effect of Procedural Fairness on Manager's Commitment

The procedural fairness is hypothesized to have a significant influence on the manager's commitment. To prove this hypothesis, the testing based on the survey data can be seen in table 8 below:

Table 8. Significance Test on the Effect of Procedural Fairness (X₂) on the Manager's Commitment (Y)

Variable	Coefficient Effect	t	Critical t	Conclusion
Procedural Fairness	0.565	4.624	1.96	Positive and significant effect
Direct Effect = 31.92%		Indirect Effect = 6.95%		Total Effect = 38.87%

Source: Data Output SPSS

In table 8 shows that the path coefficient of procedural fairness to manager's commitment is 0.565. The positive relationship of procedural fairness on manager's commitment means that the higher the degree of procedural fairness, the higher the magnitude of the manager's commitment. Furthermore, the value of t-test path coefficients of procedural fairness variable on manager's commitment is 4.624. It is also found that t-test value is greater than t-table (1.96), thus concluded that procedural fairness significantly influence the managers' commitment. Meanwhile, the effect of procedural fairness on manager's commitment amounted to 38.87%. If the magnitude of this effect is interpreted based on the level of the strong relationship proposed by Guilford (1956: 145), then the effect of procedural fairness on the manager's commitment is low or weak. The results are consistent with the findings by Early and Lind

(1987), Lin et al. (1990), Wentzel (2003), Mulyasari and Sugiri (2004), Yusuf Ningrum and Ghozali (2005), which states that procedural fairness has a positive and significant effect on the manager's commitment.

This a weak effect of procedural fairness due to a variety of decision-making procedures such as the budget preparation and execution procedures, evaluation procedure of budget execution and award procedures that are often done not in timely. At the pawnshop, a variety of decision-making procedures are well formulated but the implementation is often done too late. For those pawnshop's branch offices that are geographically dispersed so widely, this delay makes the branch manager can not prepare and implement the budget properly and the corrective action is often too late when there is a deviation in the responsibility. Similarly with the provision of various forms of awards that been done in later time will not provide a meaningful value. Thus the timeliness is an important factor that must be taken into consideration in formulating and implementing decisions.

The Simultaneous Effect of Participatory Budgeting and Procedural Fairness and Manager's Commitment on Manager's Performance

The hypothesis result of simultaneous effect of participatory budgeting, procedural fairness, manager's commitment on manager's performance can be seen in table 9 below:

Table 9. The Simultaneous Effect of Participatory Budgeting (X_1) and Procedural Fairness (X_2) and Manager's Commitment (Y) to Manager's Performance (Z)

Variable	Coefficient Effect	Direct Effect	Indirect Effect	Total
(X_1)	0.471	22.18%	13.61%	35.79%
(X_2)	0.351	12.32%	13.17%	25.49%
(Y)	0.296	8.76%	14.73%	23.49%
Total Effect Simultaneously				84.77%
Other Variable on Z				15.23%

Source: Data Output SPSS

The analysis showed that the participatory budgeting, procedural fairness and manager's commitment affect simultaneously the manager's performance. The influence of these three variables to the manager's performance is positive at 84.77%. The results of this study indicate that the magnitude of the manager's performance can be explained by the participatory budgeting, procedural fairness and manager's commitment, while 15.23% is explained by other variables. If the magnitude of this effect is interpreted based on the level of relationship strength proposed by Guilford (1956: 145), the participatory budgeting, procedural fairness and manager's commitment are having strong effect. Moreover, the effect of participatory budgeting variable was greater than the variables of procedural fairness and manager's commitment. In this regard, the efforts to increase manager's performance is to increase the participation of managers in the preparation of the budget. Increased in participation is very important with consideration that they are the most knowledgeable both the potential and weaknesses of the organization unit, so that they will develop a more realistic plan in accordance with the conditions and the ability of the organization unit.

The Effect of Participatory Budgeting on Manager's Performance

The participatory budgeting is hypothesized to have a significant influence on the manager's performance. To prove this hypothesis, the testing based on the survey data can be seen in table 10 below:

Table 10. Significance Test on the Effect of Participatory Budgeting (X_1) on Manager's Performance (Z)

Variable	Coefficient Effect	t	Critical t	Conclusion
Participatory Budgeting	0.471	3.564	1.96	Positive and significant effect
Direct Effect = 22.18%		Indirect Effect = 13.61%		Total Effect = 35.79%

Source: Data Output SPSS

In table 10 shows that the path coefficient of participatory budgeting to manager's performance is 0.471. The positive relationship of participatory budgeting on manager's performance means that the higher the degree of participatory budgeting, the higher the magnitude of the manager's performance. Furthermore, the value of t-test path coefficients of participatory budgeting variable on manager's performance is 3.564. It is also found that t-test value is greater than t-table (1.96), thus concluded that participatory budgeting significantly influence the managers' performance. Meanwhile, the effect of participatory budgeting on manager's performance amounted to 35.79%. If the magnitude of this effect is interpreted based on the level of the strong relationship proposed by Guilford (1956: 145), then the effect of participatory budgeting on the manager's performance is low or weak. The results are consistent with the findings by Shields et al. (2000), Chong and Chong (2002), Wentzel (2002) which states that participatory budgeting has a positive and significant effect on the manager's performance. This a weak effect of participatory budgeting describe the awareness of branch managers that achievement is an obligation and thus the related activities should always be done, so as not to affect the level of the authority given by their superior manager in the preparation of the budget.

The Effect of Procedural Fairness on Manager's Performance

The procedural fairness is hypothesized to have a significant influence on the manager's performance. To prove this hypothesis, the testing based on the survey data can be seen in table 11 below:

Table 11. Significance Test on the Effect of Procedural Fairness (X₂) on Manager's Performance (Z)

Variable	Coefficient Effect	t	Critical t	Conclusion
Procedural Fairness	0.351	3.136	1.96	Positive and significant effect
Direct Effect = 12.32%		Indirect Effect = 13.17%		Total Effect = 25.49%

Source: Data Output SPSS

In Table 10 shows that the path coefficient of procedural fairness to manager's performance is 0.351. The positive relationship of procedural fairness on manager's performance means that the higher the degree of participatory budgeting, the higher the magnitude of the manager's performance. Furthermore, the value of t-test path coefficients of procedural fairness variable on manager's performance is 3.136. It is also found that t-test value is greater than t-table (1.96), thus concluded that procedural fairness significantly influence the managers' performance. Meanwhile, the effect of procedural fairness on manager's performance amounted to 25.49%. If the magnitude of this effect is interpreted based on the level of the strong relationship proposed by Guilford (1956: 145), then the effect of procedural fairness on the manager's performance is low or weak. The results are consistent with the findings by Libby (1999), Wentzel (2002), Mulyasari and Sugiri (2004) which states that procedural fairness has a positive and significant effect on the manager's performance.

This a weak effect of procedural fairness due a tendency of branch office managers that they feel less given the opportunity to express their opinions in the decision-making process of the organization, so their drive to excel also low. Thus, the improvement of manager's performance can be done by providing a greater opportunity in organizational decision-making procedure. Increases the magnitude of the manager's participation in decision-making enabling them to determine the overall decision-making process of the organization, so as to produce the information relevant to the job. The job relevant information is related to the extent of manager's assessment ability to receive the information that can be used in effective decision making as well as to evaluate the alternative decision. This also can improve the performance because it provides more accurate predictions on the environment and a more effective choice for the best action.

The Effect of Manager's Commitment on Manager's Performance

The manager's commitment is hypothesized to have a significant influence on the manager's performance. To prove this hypothesis, the testing based on the survey data can be seen in table 12 below:

Table 12. Significance Test on the Effect of Manager's Commitment (Y) on Manager's Performance (Z)

Variable	Coefficient Effect	t	Critical t	Conclusion
Commitment	0.296	2.450	1.96	Positive and significant effect
Direct Effect = 8.76%		Indirect Effect = 14.73%		Total Effect = 23.49%

Source: Data Output SPSS

In Table 12 shows that the path coefficient of commitment to manager's performance is 0.296. The positive relationship of commitment on manager's performance means that the higher the degree of commitment, the higher the magnitude of the manager's performance. Furthermore, the value of t-test path coefficients of commitment variable on manager's performance is 2.450. It is also found that t-test value is greater than t-table (1.96), thus concluded that commitment significantly influence the managers' performance. Meanwhile, the effect of commitment on manager's performance amounted to 23.49%. If the magnitude of this effect is interpreted based on the level of the strong relationship proposed by Guilford (1956: 145), then the effect of commitment on the manager's performance is low or weak. The commitment is closely related to the manager's performance. Accordingly, the higher the commitment of managers, it will be the higher the performance. Results of the study show that the effect of the manager's commitment to performance is still low which due to limitation on the given budget, so their performance becomes low. Accordingly, the upper-level managers attempt to increase the lower level manager's commitment and suggested to continue fulfilling the expectations that will foster the satisfaction or pride in them. The results are consistent with research conducted by Murray (1990), Chong and Chong (2002), Wentzel (2002), Yusufah Ningrum and Ghazali (2005) which states the manager's commitment has a positive and significant effect to performance.

Given the manager's commitment is an intervening variable, efforts to increase the commitment is also influenced by the interaction of the previous independent variables, namely participatory budgeting and procedural fairness. Thus, efforts to increase the manager's commitment on the goals of the budget can be done by increasing their participation in the preparation of the budget. Through this participation, the managers will have high motivation to achieve its stated objectives. Other efforts that can be done is to give a wider opportunity to branch manager in the decision making process of the organization.

5 Conclusions

Based on the results and discussion, the research conclusions can be stated as follows:

1. Participatory budgeting and procedural fairness simultaneously have a significant and positive effect to the manager's commitment.
2. Participatory budgeting has a significant positive effect on managers' commitment.
3. Procedural fairness has a significant and positive effect on managers' commitment.
4. Participatory budgeting and procedural fairness and commitment simultaneously have a significant and positive effect on the manager's performance.
5. Participatory budgeting has a significant and positive effect on the manager's performance.
6. Procedural fairness has a significant and positive effect on the manager's performance.
7. Commitment has a significant and positive effect on the manager's performance.

References

1. Anthony, N. R., & Vijay, G. (2003). *Management Control System*. Irwin-McGraw-Hill.
2. Binberg, J., Shields, M., & Mc Innes. (1986). Budgetary Participation, Motivation and Managerial Performance. *The Accounting Review*, 9(4), 587-600.
3. Cropanzano, R., & Folger, R. (1991). *Procedural Justice and Worker Motivation, In Motivation and Work Behavior*. Edited by R.M. Staw, & L.W. Porter. New York, NY: McGraw-Hill.

4. Chong, Vincent, K., & Ming, C.K. (2002). Budget Goal Commitment and Informational Effects of Budget Participation on Performance: A Structural Equation Modeling Approach. *Behavioral Research in Accounting*, 14
5. Folger, R.D., Rosenfeld & Robinson, T. (1983). Relative Deprivation and Procedural Justification. *Journal of Personality and Social Psychology*, 45, 268-273.
6. Ferdinand, A. (2000). *Structural Equation Modeling Dalam Penelitian Manajemen*. Aplikasi Model Model Rumit Dalam Penelitian Untuk Tesis S-2 & Disertasi S-3 (Application of Research Models). Badan Penerbit Universitas Diponegoro, Semarang.
7. Govindarajan, V. (1986). Impact of Participation in Budgetary Process on Attitudes and Performance: Universalistic and Contingency Perspectives. *Decisions Sciences*, 196-516.
8. Guilford, J.P. (1956). *Psychometric Method*. New York: McGraw-Hill Book Company Inc.
9. Hollebeck, John R., Charles R., Williams, & Howard, J. K. (1989). An Empirical Examination of The Antecedents of Commitment to Difficult Goals. *Journal of Applied Psychology*, 18-23.
10. Hansen, Don R., & Maryanne M. Mowen, (2005). *Management Accounting*, 7th USA, International, Thomson Publishing.
11. Kennis, Izzetin, 1979. Effect of Budgetary Goal Characteristic on Managerial Attitudes and Performance. *The Accounting Review*, Vol 47 (4) pp 707-721.
12. Weitner, R., & Angelo K. (2000). *Organizational Behavior*. Mc Graw-Hill Companies, New York.
13. Libby, T. (1999). The Influence of Voice and Explanation on Performance in A Participative Budgeting Setting. *Accounting, Organizations and Society*, 24, 125-137.
14. Lindquist, T. M. (1995). Fairness as Antecedent to Participative Budgeting: Examining The Effects of Distrutive Justice, Procedural Justice and Referent Cognition on Satisfaction and Performance. *Journal of Management Accounting Research*, 7, 122-142.
15. Ariyanto (2004). Perum Pegadaian: Selayang Pandang Sejarah Pegadaian.
16. Milani, K. (1975). The Relationship of Participation in Budget Setting to Industrial Supervisor Performance and Attitude: A Field Study. *The Accounting Review*.
17. Murray, D. (1990). The Performance Effect of Participative Budgeting: An Integration of Intervening and Moderating Variables. *Behavioral Research in Accounting*, 104-123.
18. Mulyasari, W., & Sugiri, S. (2005). Keadilan, Komitmen Pada Tujuan, dan Job Relevant Information dalam Penganggaran Partisipatif. *Jurnal Riset Akuntansi Indonesia*, 8(3), 310-324.
19. Otley, D. (1978). Budget Use and Managerial Performance. *Journal Accounting Research*, 16, 122-149.
20. Shields, J.F. & Shields (1998). Antecedents of Participative Budgeting. *Accounting, Organization and Society*, 49-76.
21. Shields, M. D., & Young (1993). Antecedents and Consequences of Participative Budgeting: Evidence on the Effects of Asymmetrical Information. *Journal of Management Accounting Research*, 265-280.
22. Shields, M. D., Deng, Johny, F., & Kato, Y. (2000). The Design and Effects of Control Systems: Test of Direct-and Indirect-Effects Models. *Accounting Organizations and Society*, 25, 185-202.
23. Siegel, G., & Helena Ramanauskas-Marconi (1989). *Behavioral Accounting*. Cincinnati: South Western Publications Company.
24. Singarimbun, M., & Effendi, S. (1995). *Metode Penelitian Survey*. Edisi Revisi, LP3ES, Jakarta.
25. Widia, A. (2012). Pengaruh Lingkungan Bisnis terhadap Informasi Akuntansi Manajemen, dan Penganggaran dampaknya terhadap Kinerja Perusahaan. *Trikonomika*, Fakultas Ekonomi Universitas Pasundan, 11/11, Dikreditasi Dikti Nomor 110/DIKTI/Kep/ 2009, 11, 160-175
26. Wentzel, K. (2002). The Influence of Fairness Perceptions and Goal Commitment on Managers Performance in A Budget Setting. *Behavioral Research in Accounting*, 14, 247-271.
27. Yusufaningrum, Kusnasriyati & Ghozali, I. (2005). Analisis Pengaruh Partisipasi Anggaran Terhadap Kinerja Manajerial Melalui Komitmen Tujuan Anggaran dan Job Relevant Information Sebagai Variabel Intervening. Kumpulan Materi Simposium Nasional Akuntansi, Solo, 15-16 September 2005, 656-666.

ORIGINALITY REPORT

21%

SIMILARITY INDEX

18%

INTERNET SOURCES

14%

PUBLICATIONS

11%

STUDENT PAPERS

PRIMARY SOURCES

1

Submitted to CSU, San Jose State University

Student Paper

2%

2

www.allbusiness.com

Internet Source

2%

3

repository.unimal.ac.id

Internet Source

2%

4

jml2012.indexcopernicus.com

Internet Source

2%

5

ifrnd.org

Internet Source

1%

6

Submitted to University of Southern
Queensland

Student Paper

1%

7

Submitted to Birkbeck College

Student Paper

1%

8

Submitted to University of North Texas

Student Paper

1%

9

www.scribd.com

Internet Source

1%

10

Submitted to Bocconi University

Student Paper

1%

11

bradscholars.brad.ac.uk

Internet Source

1%

12

Submitted to American Public University
System

Student Paper

<1%

13

issuu.com

Internet Source

<1%

14

Submitted to Macquarie University

Student Paper

<1%

15

pdfs.semanticscholar.org

Internet Source

<1%

16

docslide.us

Internet Source

<1%

17

www.pradnya.ac.id

Internet Source

<1%

18

insipub.org

Internet Source

<1%

19

jurnalnasional.ump.ac.id

Internet Source

<1%

repository.usu.ac.id

20

Internet Source

<1%

21

Submitted to London School of Economics and Political Science

Student Paper

<1%

22

Maksum, Azhar, Rustam Hamid, and Iskandar Muda. "The Impact of Treasurer's Experience And Knowledge on The Effectiveness of The Administration and Preparation of The Accountability Reporting System in North Sumatera", Asian Journal of Finance & Accounting, 2014.

Publication

<1%

23

Submitted to Universitas Brawijaya

Student Paper

<1%

24

Submitted to Austrian Institute of Management SA

Student Paper

<1%

25

Submitted to President University

Student Paper

<1%

26

snp2m2017.poliupg.ac.id

Internet Source

<1%

27

Submitted to Emirates College of Technology

Student Paper

<1%

28

www.mustdbms.com

Internet Source

<1%

29

www.iiste.org

Internet Source

<1%

30

fedetd.mis.nsysu.edu.tw

Internet Source

<1%

31

F. Schwarz. "An Approximation Scheme for Constructing $\pi^\circ\pi^\circ$ Amplitudes from ACU Requirements", Fortschritte der Physik, 1980

Publication

<1%

32

"Learn How to Present Financial Reports and Budgets with Confidence with New e-Learning Course.", Business Wire, Nov 9 2006 Issue

Publication

<1%

33

www.aaajournals.org

Internet Source

<1%

34

Submitted to University of Greenwich

Student Paper

<1%

35

www.matec-conferences.org

Internet Source

<1%

36

Phyllis A. Siegel. "The Moderating Influence of Procedural Fairness on the Relationship Between Work-Life Conflict and Organizational Commitment.", Journal of Applied Psychology, 2005

<1%

37

Submitted to University of Durham

Student Paper

<1%

38

www.baa.group.shef.ac.uk

Internet Source

<1%

39

uad.portalgaruda.org

Internet Source

<1%

40

Libby, T.. "The influence of voice and explanation on performance in a participative budgeting setting", Accounting, Organizations and Society, 199902

Publication

<1%

41

Kevin E. Dow, Marcia W. Watson, Penelope S. Greenberg, Ralph H. Greenberg. "Understanding Participation: Situational Participation, Intrinsic Involvement, and Influence", Emerald, 2012

Publication

<1%

42

Chong M. Lau, Sharon L.C. Tan. "The effects of procedural fairness and interpersonal trust on job tension in budgeting", Management Accounting Research, 2006

Publication

<1%

43

Nace R. Magner, Gary G. Johnson, Harold T. Little, A. Blair Staley, Robert B. Welker. "The case for fair budgetary procedures",

<1%

-
- | | | |
|----|---|-----|
| 44 | Submitted to RMIT University
Student Paper | <1% |
|----|---|-----|
-
- | | | |
|----|------------------------------|-----|
| 45 | aaahq.org
Internet Source | <1% |
|----|------------------------------|-----|
-
- | | | |
|----|---------------------------------|-----|
| 46 | docobook.com
Internet Source | <1% |
|----|---------------------------------|-----|
-
- | | | |
|----|--|-----|
| 47 | online-journal.unja.ac.id
Internet Source | <1% |
|----|--|-----|
-
- | | | |
|----|-----------------------------------|-----|
| 48 | akuntansia.com
Internet Source | <1% |
|----|-----------------------------------|-----|
-
- | | | |
|----|---|-----|
| 49 | Brockner, J.. "High procedural fairness heightens the effect of outcome favorability on self-evaluations: An attributional analysis", Organizational Behavior and Human Decision Processes, 200305
Publication | <1% |
|----|---|-----|
-
- | | | |
|----|--|-----|
| 50 | repository.syekhnurjati.ac.id
Internet Source | <1% |
|----|--|-----|
-
- | | | |
|----|--|-----|
| 51 | Lau, C.M.. "The effects of procedural fairness and interpersonal trust on job tension in budgeting", Management Accounting Research, 200606
Publication | <1% |
|----|--|-----|
-

52

www.researchgate.net

Internet Source

<1%

53

Maria A. Leach-López, William W. Stammerjohan, Eunsuh Lee, Claire Allison Stammerjohan. "Relationship of budget participation conflict and job performance of South Korean managers", *Cross Cultural Management: An International Journal*, 2015

Publication

<1%

54

Yen-Ting Chen, Tsung-Yu Chou. "Exploring the continuance intentions of consumers for B2C online shopping", *Online Information Review*, 2012

Publication

<1%

55

Zhihong Wang, James E. Hunton. "The Effect of Congruence between Cultural Time Orientation and Budget Planning Horizon on Employees' Satisfaction with Participative Budgeting", *Emerald*, 2011

Publication

<1%

56

Campus-Wide Information Systems, Volume 30, Issue 4 (2014-03-28)

Publication

<1%

57

Hafizah - -. "The Influence of Online Media and Social Media on Mass Communication with Communication Technology as Intervening Variables", *Business and Economic Research*,

<1%

2017

Publication

58

Mahfud Sholihin. "Fairness in performance evaluation and its behavioural consequences", *Accounting and Business Research*, 2009

Publication

<1%

59

Rini Anggrainingsih, Muhammad Zuhurul Umam, Haryono Setiadi. "Determining e-learning success factor in higher education based on user perspective using Fuzzy AHP", *MATEC Web of Conferences*, 2018

Publication

<1%

Exclude quotes Off

Exclude matches Off

Exclude bibliography Off